

Mounting and Operating Instructions

For

RS485 Remote Control Unit



Dear Customer!

By selecting this product you have decided to use a professional device which guarantees high quality and reliability. We'd like to thank you very much for your confidence and kindly ask you to read the following instructions carefully before commissioning in order to take full advantage of all quality features regarding this product line.

Contents

General Information

| | |
|----------------------------|---|
| Function Description | 3 |
| Scope of Delivery | 3 |
| Safety Precautions | 4 |

Connection and Configuration

| | |
|---|----|
| System Overview | 5 |
| Standard Connect | 5 |
| Control via DVR Connect | 6 |
| Standard Connect Camera System Block Diagram | 7 |
| Control via DVR Connect Camera System Block Diagram | 8 |
| Connecting the Keyboard | 9 |
| Packing Detail | 10 |

Operation

| | |
|---------------------------|----|
| Key Assignment | 11 |
| General Operation | 19 |
| Control Command | 20 |
| Function of Display | 23 |

How to connect the 256 camera system

| | |
|---------------------------|----|
| Menu Setting | 26 |
| Connection of Video | 31 |

Exhibit

| | |
|------------------------------------|----|
| Troubleshooting | 33 |
| Technical Specifications | 34 |
| Some Words on Excess-Voltage | 35 |
| Maintenance and Care | 35 |
| Technical Support | 35 |

General Information

Function Description

This external keypad controller is used for the controlling, monitoring and programming of RS485 system products.

This keypad controller comes in elegant extruded aluminum for low profile table desk housing. Due to its compact size, it can be integrated everywhere harmoniously. With this keypad controller, you can control single components as well as complex CCTV systems. Clients within the RS485 BUS are selected via the numeric keypad. Contact with the corresponding client is confirmed by an acoustic signal and additionally in the keypad's info display. Messages such as target address, type of receiver and e.g. camera movements are also shown in the display.

If you are using a matrix switcher, this is selected as central unit. Connected pan/tilt heads or high speed dome cameras are automatically enabled for control by the offset function integrated into the matrix switcher. It is not necessary to additionally address them directly.

This keypad controller comes with a robust joystick with integrated zoom function (effected by turning the joystick). This makes it be possible to control connected pan/tilt head camera stations respectively high speed dome cameras reliably and easily. Just one hand is required for tracking an object with the connected camera unit.

A potential separation with an optic-coupler (potential separator) allows trouble-free data communication on the RS485 control line.

Scope of Delivery

- Remote control unit
- 3 m connection cable
- Power adapter 230/110 VAC to 12 VDC
- Connector box
- Operation manual

Safety Precautions

1. Read these instructions carefully before connecting the components in order to avoid malfunctions and damages caused by improper installation or use.
2. Installation may only be carried out by authorized personnel according to the local safety regulations.
3. Only operate the device with the included power supply adapter and the stated operating voltage.
4. Never use the camera for other purposes except that designated.
5. Repairs and adjustments at the device may only be carried out by authorized personnel.
6. Remove the device from power supply if you do not use it for an extended period of time.
7. Immediately disconnect the device from power supply if any liquid or solid matter should get into the housing and have it checked by your authorized dealer before re-using.
8. Follow the warning notes attached to the device.
9. Only use the device in dry, dust-free and non hazardous locations.
10. Only use the device indoors.
11. In order to avoid internal heat accumulation in the device:
 - do not expose the device to direct sunlight.
 - keep sufficient distance to direct heat sources.

Connection and Configuration

System Overview

A. Standard Connect

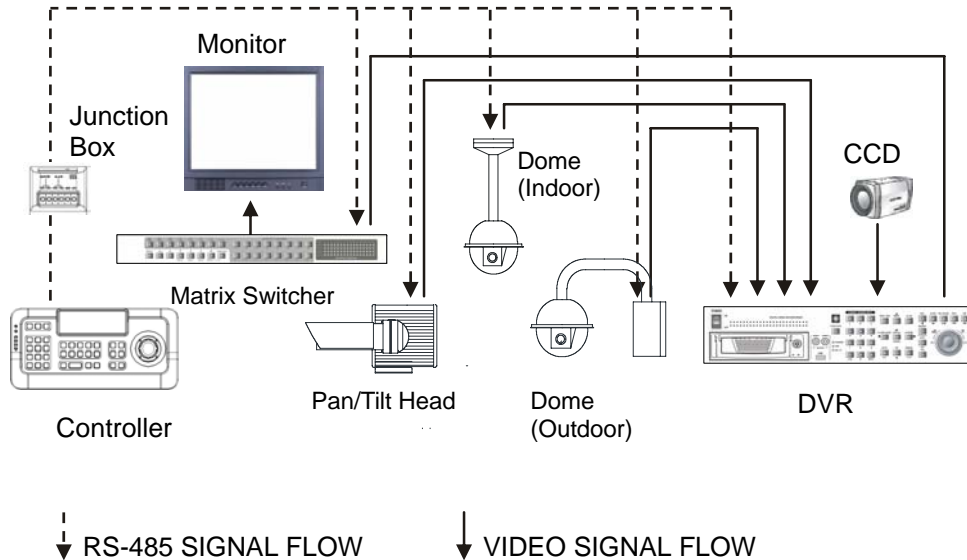

The following devices can be controlled with this keypad controller:

- Telemetry receiver for pan/tilt head
- Telemetry receiver for pan/tilt head with pre-set positions
- High speed pan/tilt head
- High speed dome for indoor use
- High speed dome for outdoor use
- Video matrix switcher (operation via RS485/232C)
- Digital video recorder for High speed domes (operation via RS485)
- The Controller manages directness the High speed domes

- Standard Connect System Block Diagram

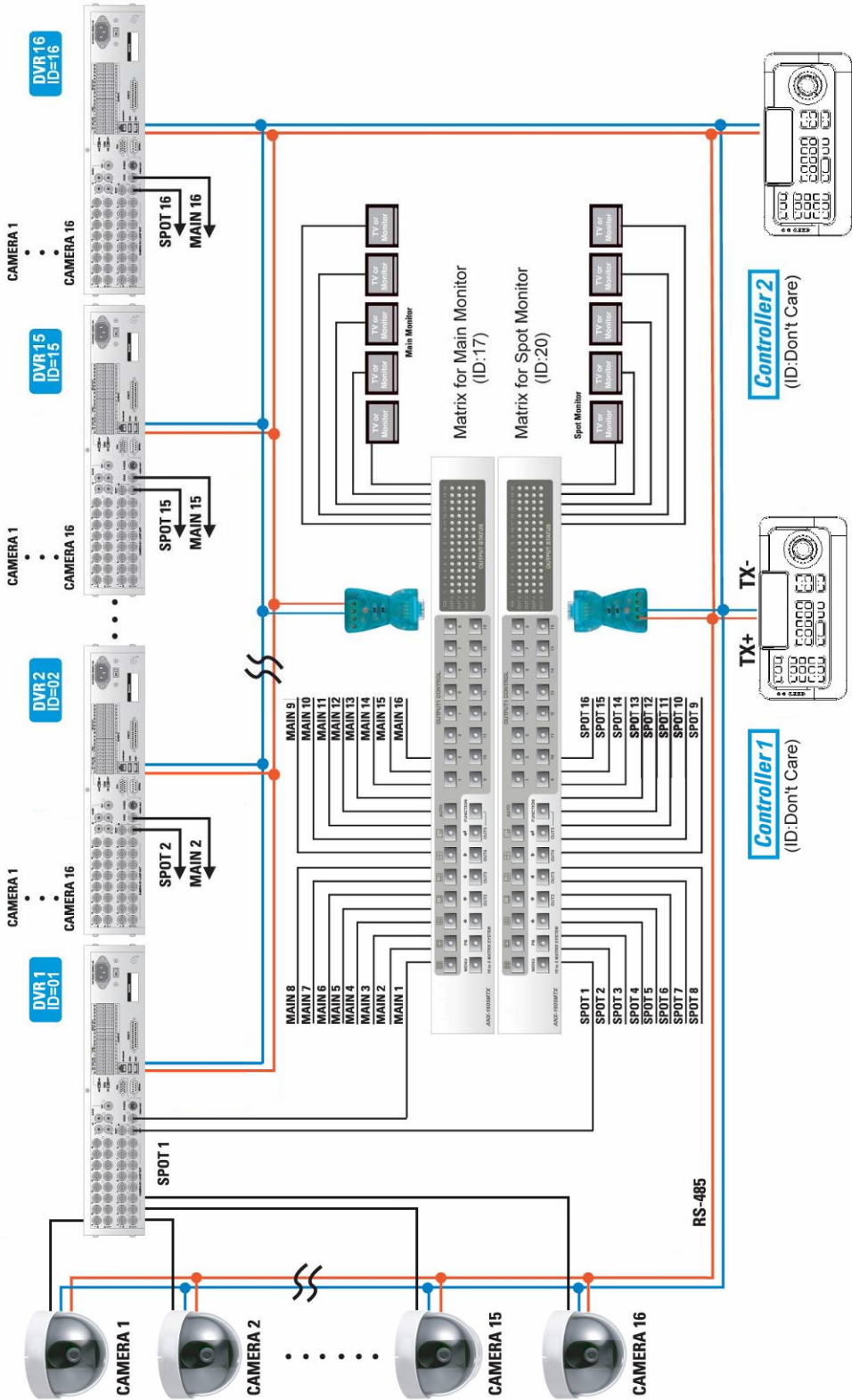

- Control via DVR Connect System Block Diagram

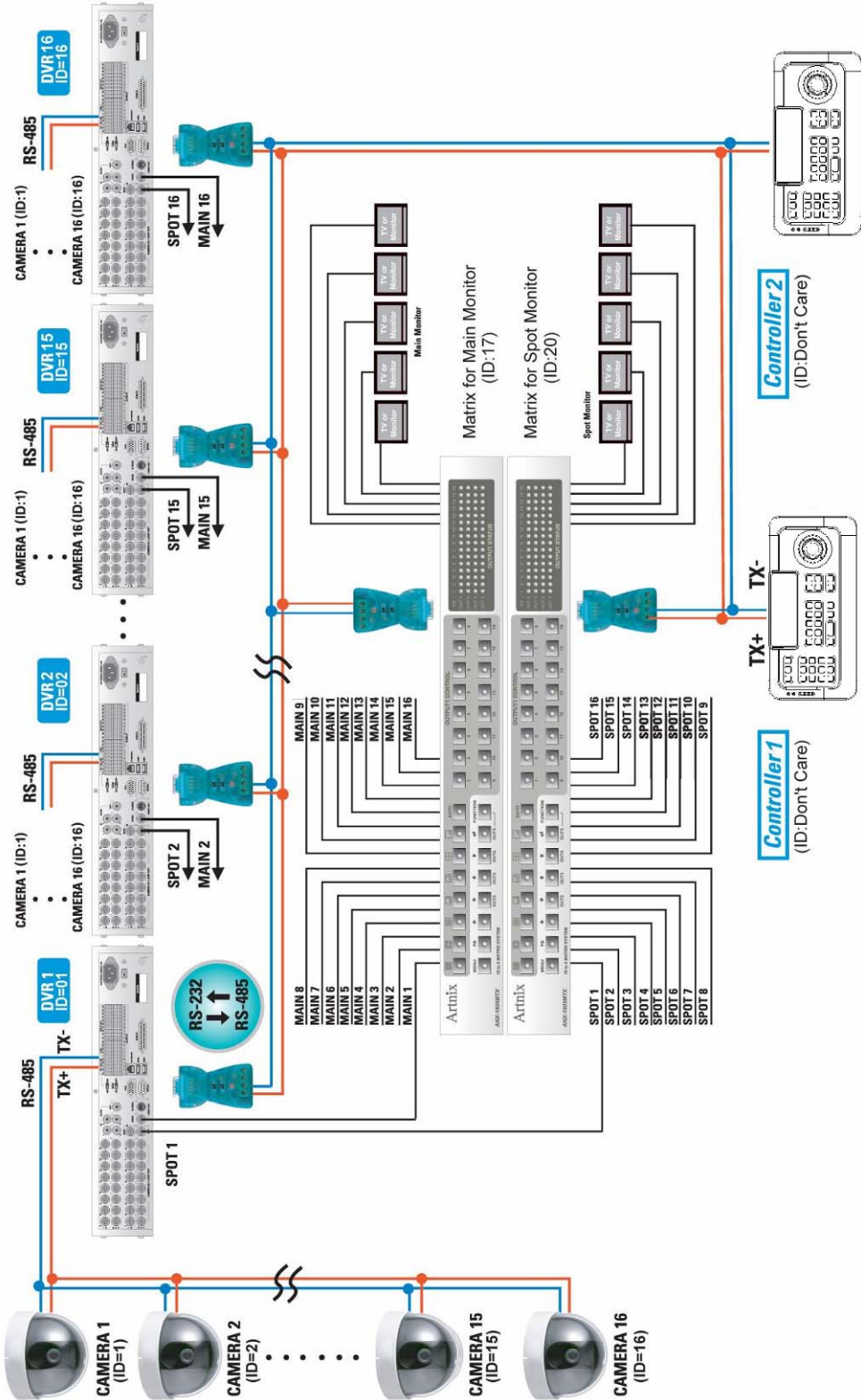

Connecting the Keyboard

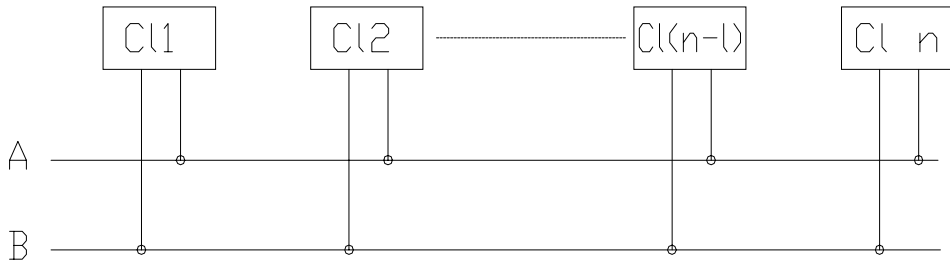

Cl = Client

The clients are connected in a parallel way to the RS485 line (conductors A and B). Up to **32 clients with a max. connection length of 6 m** can be connected to the main line.

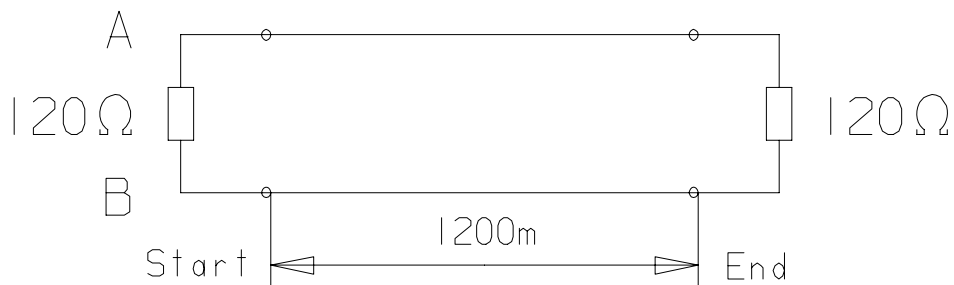

The RS485 line can have a length of up to **1200 m**. A transmission line with 120 Ohm has to be connected to the start and to the end of it in order to avoid signal reflections. The terminating resistor for the RS485 can be connected to each client with a jumper.

PACKING DETAIL

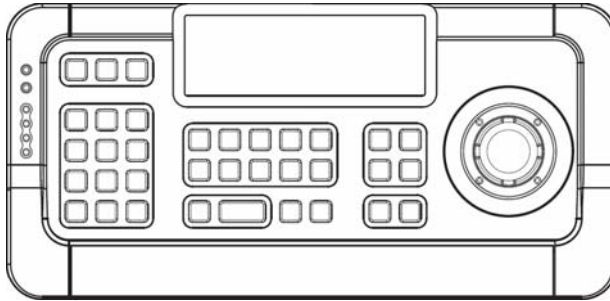

1. CONTROLLER

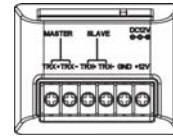

2. JUNCTION BOX

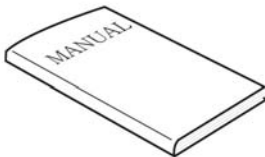

3. MANUAL



4. LAN CABLE



5. AC ADAPTOR
& POWER CORD

- Power Supply

Only operate the device with the power supply adapter (**12 V/DC**) included in the scope of delivery. Connect the power supply adapter to the keyboard's junction plug into the connector box.

The correct power supply is signaled by the LCD display.

- RS485 Interface

Connect the RS485 interface with correct polarity (TRX+ and TRX-) to the junction box.

- LAN cable (RJ45)

Connect the controller to the junction box.

Don't connect the controller to hub and network equipment.

Operation

This keypad controller can control all of RS485 devices. The corresponding key commands for controlling the individual devices are described in this chapter.

Key Assignment

Joy Stick Control

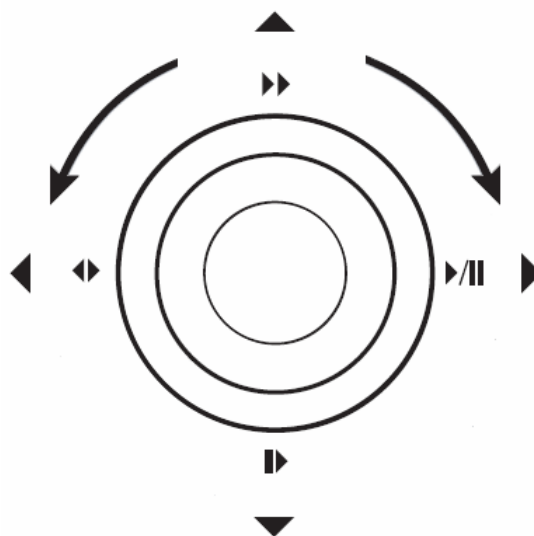
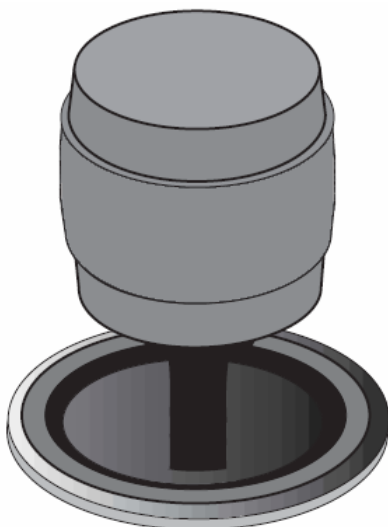

| Joy Stick Control | Operation | State | Description |
|-------------------|------------|--------------|--------------------------|
| ① ↺ | (ZOOM-) | PTZ via DVR | PTZ Zoom Control via DVR |
| | ZOOM- | PTZ | PTZ Zoom Control |
| ② ↻ | (ZOOM+) | PTZ via DVR | PTZ Zoom Control via DVR |
| | ZOOM+ | PTZ | PTZ Zoom Control |
| ③ ▲ | ▲ | Menu setup | Upper direction |
| | FAST | DVR Playback | |
| ④ ▼ | ▼ | Menu setup | Lower direction |
| | SLOW | DVR Playback | |
| ⑤ ◀ | ◀ | Menu setup | Left direction |
| | DIR | DVR Playback | Direction |
| ⑥ ▶ | ▶ | Menu setup | Right direction |
| | PLAY/PAUSE | DVR Playback | |

Quad Control Key

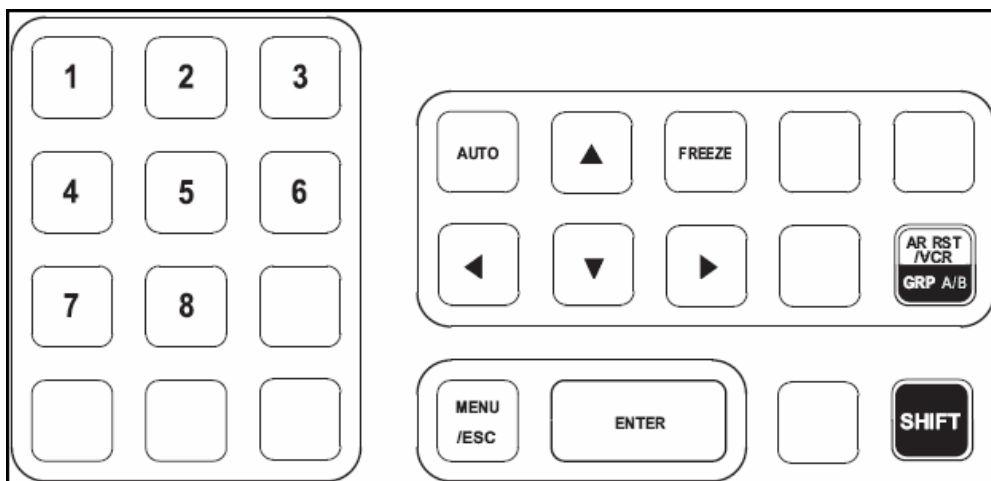

- Matrix for 128 camera system (2page Quad)

| Controller keys | Operation | Description |
|-----------------|---------------------------------|---|
| ① 1~8 | 1~8 | Numeric digit (Channel) |
| ② SPOT/ ESC | MENU/ ESC | Menu screen/ Previous menu |
| ③ ▲ | ▲ | Upper direction |
| ④ ▼ | ▼ | Lower direction |
| ⑤ ◀ | ◀ | Left direction |
| ⑥ ▶ | ▶ | Right direction |
| ⑦ LV/PB | VCR/ AR RST / GRP A/B | VCR mode/ Release the event signal / Group(page) selection |
| ⑧ STATUS | QUAD/ PIP/ ENTER | Quad mode/ PIP mode/ Enter the next step |
| ⑨ AUTO | AUTO | Auto sequence |
| ⑩ FREEZE | FREEZE | Still image |
| ⑪ SHIFT | SHIFT | Press this button to do the commands of white parts |

* **White parts**: Commands to use the “SHIFT” button

Matrix Control Key

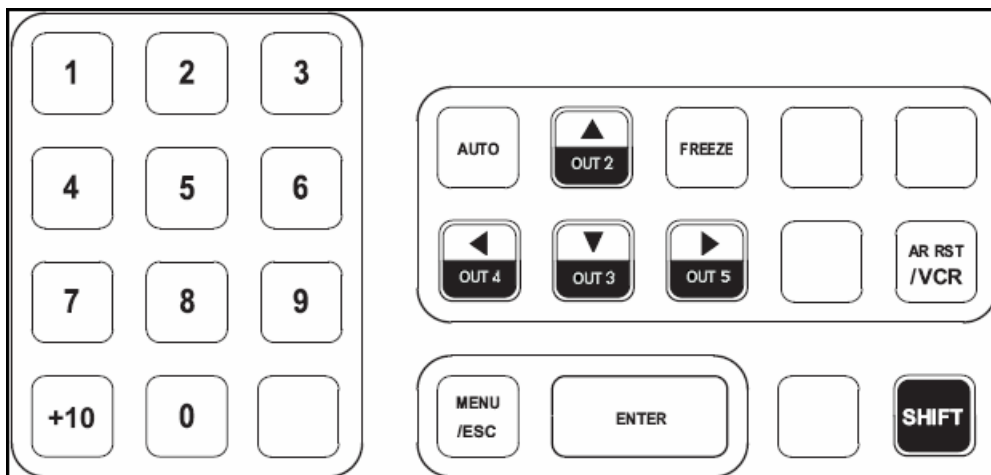

- Matrix for 256 camera system

| Controller keys | Operation | Description |
|-----------------|----------------|---|
| ① 0~9, +10 | 0~9, +10 | Numeric digit (Channel) |
| ② SPOT/ ESC | MENU/ ESC | Menu screen/ Previous menu |
| ③ ▲ | ▲/ OUT2 | Upper direction/ Monitor 2 output of matrix |
| ④ ▼ | ▼/ OUT3 | Lower direction/ Monitor 3 output of matrix |
| ⑤ ◀ | ◀/ OUT4 | Left direction/ Monitor 4 output of matrix |
| ⑥ ▶ | ▶/ OUT5 | Right direction/ Monitor 5 output of matrix |
| ⑦ LV/PB | VCR/ AR RST | VCR mode/ Release the event signal |
| ⑧ STATUS | PIP/ ENTER | PIP mode/ Enter the next step |
| ⑨ AUTO | AUTO/ - | Auto sequence/ Decrease of value |
| ⑩ FREEZE | FREEZE/ + | Still image/ Increase of value |
| ⑪ SHIFT | SHIFT | Press this button to do the commands of white parts |

PTZ via DVR Control Key

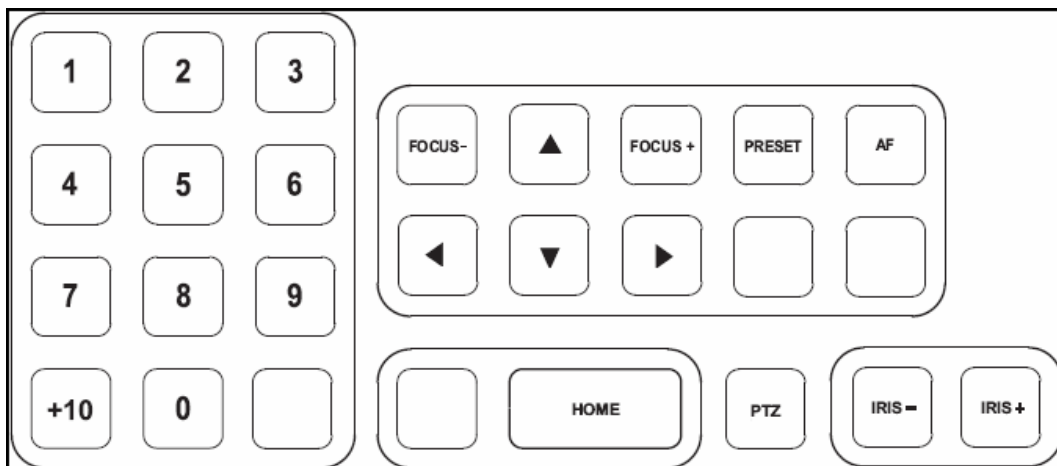

- PTZ via DVR control

| Controller key | Operation | Command |
|--------------------|------------|--------------------------|
| ① 0~9, +10 | 0~9, +10 | Numeric digit |
| ② (FOCUS-)/ AUTO | FOCUS- | Forward focus |
| ③ (FOCUS+)/ FREEZE | FOCUS+ | Backward focus |
| ④ (PRESET)/ SEARCH | PRESET | Preset |
| ⑤ (AF)/ COPY | AUTO FOCUS | Auto focus |
| ⑥ (HOME)/ STATUS | HOME | Move to Home |
| ⑦ (PTZ)/ SETUP | PTZ | DVR PTZ Mode |
| ⑧ (IRIS-)/ FOCUS- | IRIS- | Iris of PTZ camera open |
| ⑨ (IRIS+)/ FOCUS+ | IRIS+ | Iris of PTZ camera close |

PTZ Control Key

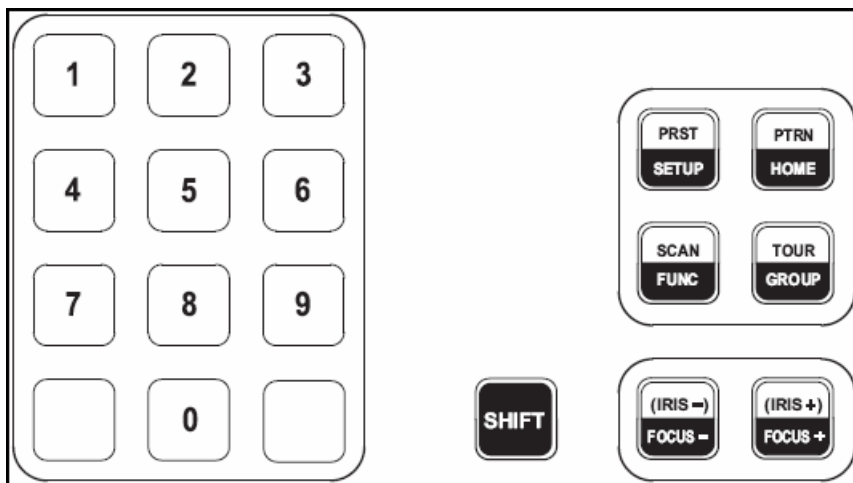

- PTZ via Controller control

| Controller key | Operation | Command |
|------------------------------|----------------------|--------------------------|
| ① 0~9 | 0~9 | Numeric digit |
| ② PRST | PRESET | Preset |
| ③ (SHIFT + PRST) | SETUP | PTZ menu setup |
| ④ PTRN | PATTERN | Pattern |
| ⑤ (SHIFT + PTRN) | HOME | Move to Home |
| ⑥ SCAN | SCAN | Scan |
| ⑦ (SHIFT + SCAN) | FUNC | Function |
| ⑧ TOUR | TOUR | Tour |
| ⑨ (SHIFT + TOUR) | GROUP | Group |
| ⑩ (IRIS-) | IRIS- | Iris of PTZ camera open |
| ⑪ (IRIS+) | IRIS+ | Iris of PTZ camera close |
| ⑫ (SHIFT + IRIS-) | FOCUS- | Forward focus |
| ⑬ (SHIFT + IRIS+) | FOCUS+ | Backward focus |
| ⑭ (SHIFT + (IRIS-) (IRIS+)) | FOCUS- FOCUS+ | Auto focus |
| ⑮ ENTER | | |

②~⑨ is only PTZ button. It is changed with the PTZ mode of the controller mode.

Controller Menu setup Key

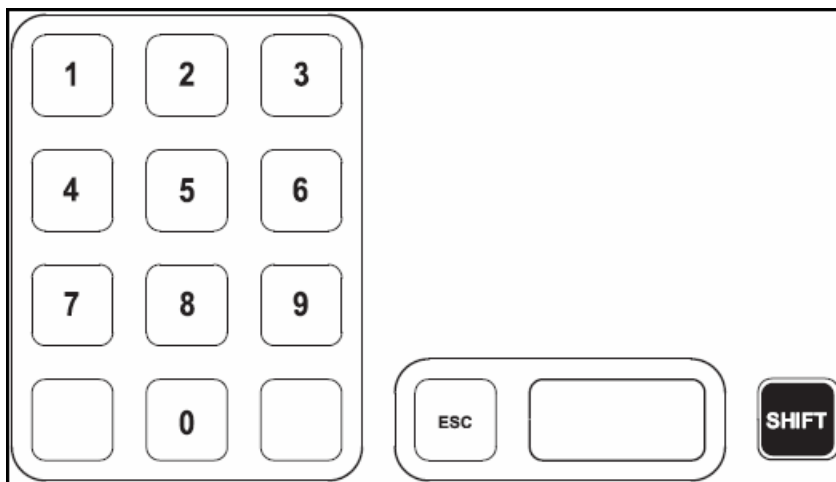

- Controller Menu setup control

| Controller key | Operation | Command |
|----------------|-----------|---|
| ① 0~9 | 0~9 | Numeric digit |
| ② SPOT/ESC | ESC | Exit menu |
| ③ SHIFT | SHIFT | Press this button to do the commands of white parts |

NOTE: Monitor output 2~5 of matrix can be displayed only full screen or 4 split screen (QUAD A~D). And if you want to display different channels in each monitor, you have to select channels of different DVR. If you select a channel in same DVR, selected channel will be displayed in all connected monitors.

* **White parts** - This character uses “SHIFT” button.

- Keypad controller

| Control keys | Description |
|---|--|
| ① MODE SEL | Mode selection |
| ② ID | ID selection |
| ③ MON | Monitor selection |
| ④ 1~9 | Numeric digit (Channel/ ID selection and password input) |
| ⑤ 0/ AUDIO SEL | Numeric digit (Channel/ ID selection and password input)/ Audio selection |
| ⑥ +10 | Numeric digit |
| ⑦ CAM/ MULTI | Camera selection/ Multi-screen selection |
| ⑧ AUTO/ - / (F-)/ RELAY4 OFF | Auto sequence mode/ Decrease of value / Focus control in DVR-PTZ mode/ Close the relay 4 in "USER" mode |
| ⑨ FREEZE/ + / (F+)/ RELAY4 ON | Still image/ Increase of value / Focus control in DVR-PTZ mode/ Open the relay 4 in "USER" mode |
| ⑩ MENU/ ▲ | Menu screen/ Upper direction |
| ⑪ PIP/ ▼ | PIP mode/ Lower direction |
| ⑫ AR RST/ ◀ | Release the event signal/ Left direction |
| ⑬ D-ZOOM/ ▶ | Digital zoom control/ Right direction |
| ⑭ SEARCH/(PRESET) | Search menu/ Preset in DVR-PTZ mode |
| ⑮ COPY/ (AF) | Copy menu/ Auto Focus in DVR-PTZ mode |
| ⑯ REC | Recording/ Stop recording |
| ⑰ LV/PB | Real view mode/ Playback mode |
| ⑱ SPOT/ ESC | Spot mode/ Previous menu |
| ⑲ STATUS/ ENTER | DVR status display/ Enter the next step |
| ⑳ (PTZ)/ SETUP | DVR-PTZ mode/ Controller menu |
| ㉑ SHIFT | Press this button to do the commands of white parts |
| ㉒ PRESET/ SETUP | Preset in CTRL-PTZ mode/ CTRL-PTZ menu |
| ㉓ PATTERN/ HOME | Pattern in CTRL-PTZ mode/ Home in CTRL-PTZ mode |
| ㉔ SCAN/ FUNC | Scan in CTRL-PTZ mode/ Function in CTRL-PTZ mode |
| ㉕ TOUR/ GROUP | Tour in CTRL-PTZ mode/ Group in CTRL-PTZ mode |
| ㉖ (IRIS-)/ FOCUS- | Iris close in CTRL-PTZ or DVR-PTZ mode/ Focus |
| ㉗ (IRIS+)/ FOCUS+ | Iris open in CTRL-PTZ or DVR-PTZ mode/ Focus |
| ㉘ FAST | Playback speed up (Up) |
| ㉙ SLOW | Playback speed down (Down) |
| ㉚ PLAY DIR | Change of playback direction (Left) |
| ㉛ PB/ PAUSE | Playback/ Pause (Right) |
| ㉜ ZOOM- | Zoom control in DVR-PTZ or CTRL-PTZ mode |
| ㉝ ZOOM+ | Zoom control in DVR-PTZ or CTRL-PTZ mode |

Keypad controller key

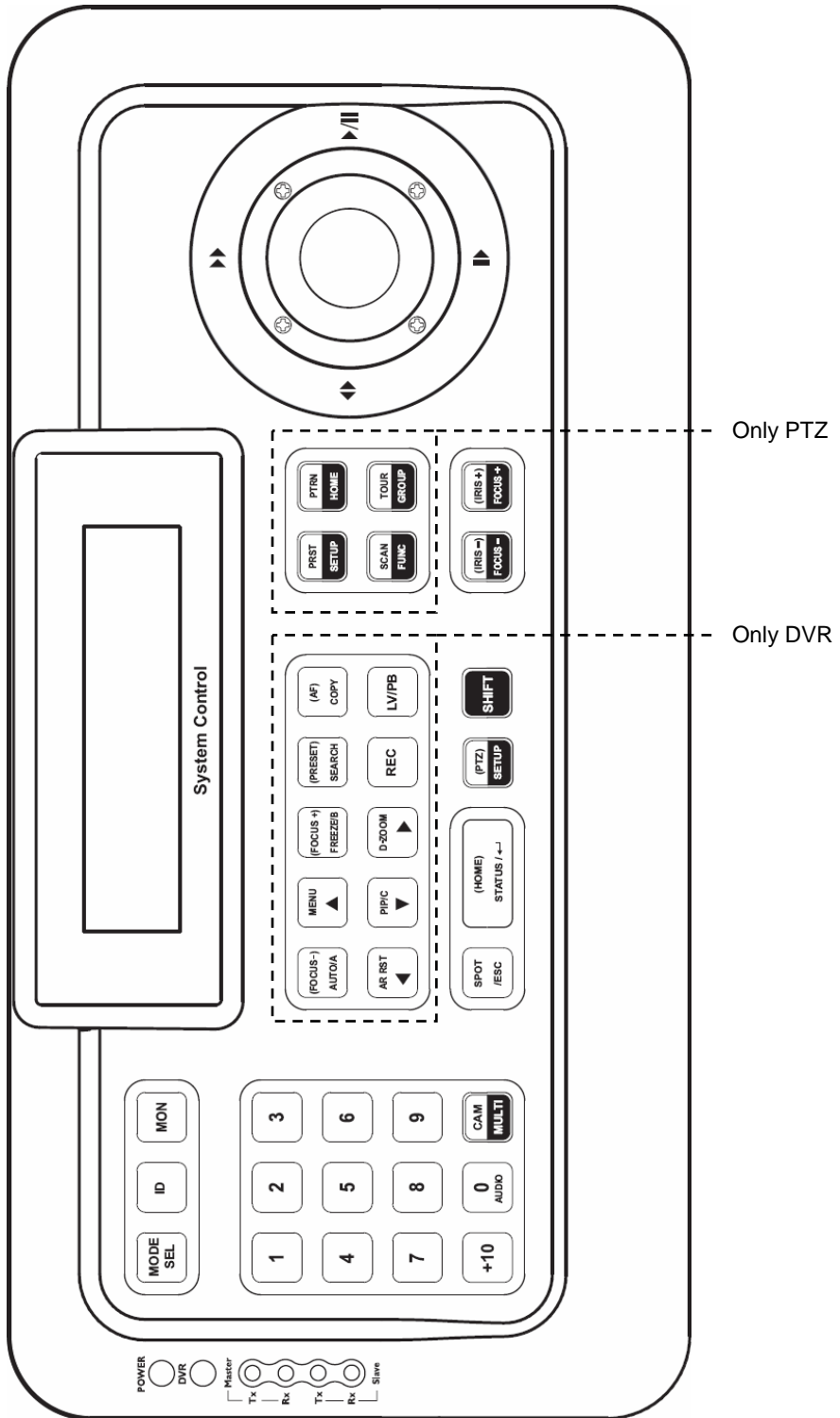

General Operation

Camera selection:

Press the "CAM" button and you can see the cursor next to "SELECT CAMERA" in LCD window. And press the desired camera number button and then press the "CAM" button again.

*NOTE: - Press the "ESC" button to revise the input value.
- You can use 1~3 digit. The controller will make a "beep" sound and the input value will be erased if you input 4 digits.*

Spot camera selection

Press the "CAM" button and then the "SPOT" button to select the spot channel.

And press the desired camera number button and then the "CAM" button again.

*NOTE: - Press the "ESC" button to revise the input value.
- You can use 1~3 digit. The controller will make a "beep" sound and the input value will be erased if you input 4 digits.
- If selected camera is PTZ camera, enter the PTZ mode automatically.
(In case of setting PTZ camera in DVR)*

ID selection:

Press the "ID" button and then select the desired number button.

ID means system ID of DVR or Quad/Matrix. (from 01 to 99)

- ID 01~16: DVR 1~16
- ID 17~19: Main monitor 1~3 of Quad/Matrix
- ID 20~22: Spot monitor 1~3 of Quad/Matrix

*NOTE: Use 2 digits when inputting ID.
For example, if you want ID number "2", you have to input "02".*

Controller menu

It changed the set of controller regulation to respect.

(Communication speed/ ID of connected devices)

Press the "SHIFT" button and then the "(PTZ) SETUP" button.

Select the desired value using the joy stick.

Press the "SPOT/ ESC" button to exit this menu. (Saving the revised data automatically)

Control Command

- Keypad controller

| Command | Controller key |
|-------------------------------|--|
| Controller menu | SHIFT + (PTZ) SETUP |
| DVR or PTZ selection | MODE SEL |
| ID selection | ID + NUMBER(01~99) |
| Display of single camera | CAM + NUMBER + CAM |
| Display of single spot camera | CAM + SPOT + NUMBER + CAM |
| Output monitor selection | MON + NUMBER (2:V2 / 3:V3 / 4:V4 / 5:V5) + NUMBER(channel no.) + MON |
| Output spot monitor selection | MON + SPOT + NUMBER (2:V2 / 3:V3 / 4:V4 / 5:V5) + NUMBER(channel no.) + MON |

- DVR control

| Command | Controller key |
|--------------------------|---------------------------------|
| Spot channel selection | SPOT + NUMBER |
| Live or Playback | LV/PB |
| Playback direction | PLAY DIR(lower joy stick left) |
| Playback / Pause | PB/PAUSE(lower joy stick right) |
| Fast playback | FAST(lower joy stick up) |
| Slow playback | SLOW(lower joy stick down) |
| DVR setup menu | MENU |
| Display digital zoom | D-ZOOM |
| Auto sequence | AUTO |
| Still image | FREEZE |
| DVR system information | STATUS |
| 1~9CH selection | NUMBER |
| 10~16CH selection | +10 + NUMBER |
| Display of multi-channel | SHIFT + MULTI |
| Recording start & stop | REC |
| Search menu | SEARCH |
| Copy menu | COPY |

OPERATION

- PTZ via DVR control

| Command | Controller key |
|--------------------------|----------------------|
| PTZ mode on/off | (PTZ) |
| Iris of PTZ camera open | (IRIS-) |
| Iris of PTZ camera close | (IRIS+) |
| PTZ menu setup | SHIFT + MENU |
| Forward focus | (FOCUS+) |
| Backward focus | (FOCUS-) |
| Auto focus | (AF) |
| Preset & Move | (PRESET) |
| Speed up | SHIFT + AUTO |
| Speed down | SHIFT + FREEZE |
| Forward zoom | Joy stick left turn |
| Backward zoom | Joy stick right turn |

- Key board control for High speed dome

| Command | Controller key |
|--------------------------|--|
| Preset | PRST |
| PTZ menu setup | SETUP (SHIFT + PRST) |
| Iris of PTZ camera open | (IRIS-) |
| Iris of PTZ camera close | (IRIS+) |
| Forward focus | FOCUS+ (SHIFT + IRIS+) |
| Backward focus | FOCUS- (SHIFT + IRIS-) |
| Auto focus | FOCUS- + FOCUS+ (SHIFT + (IRIS-)(IRIS+)) |
| Pattern | PTRN |
| Home | HOME (SHIFT + PTRN) |
| Scan | SCAN |
| Function | FUNC (SHIFT + SCAN) |
| Tour | TOUR |
| Group | GROUP (SHIFT + TOUR) |
| Forward zoom | Joy stick left turn |
| Backward zoom | Joy stick right turn |

- Matrix control for 256 camera system

| Command | Controller key |
|-------------------------------------|---|
| ID selection (256 Camera System) | ID + NUMBER(01~16) (Main Monitor:17/ Spot Monitor:20) |
| Menu / Escape | SPOT/ESC |
| Enter the next step | ENTER |
| Move cursor | direction key(▲▼◀▶) / joy stick(▲▼◀▶) |
| Change Value | AUTO/- , FREEZE/+ |
| VCR / Alarm reset | AR RST |
| Auto sequence | AUTO/- |
| Still image | FREEZE/+ |
| Camera Selection of Output 1 | NUMBER |
| Camera Selection of Output 2 | MON + 2 + NUMBER |
| Camera Selection of Output 3 | MON + 3 + NUMBER |
| Camera Selection of Output 4 | MON + 4 + NUMBER |
| Camera Selection of Output 5 | MON + 5 + NUMBER |

- Matrix control for 128 camera system (2page quad)

| Command | Controller key |
|-------------------------------------|--|
| ID selection (128 Camera System) | ID + NUMBER(01~08) (Main Monitor:17 / Spot Monitor:20) |
| Menu / Escape | SPOT/ ESC |
| Enter the next step | ENTER |
| Move cursor | direction key(▲▼◀▶) / joy stick(▲▼◀▶) |
| Change Value | ENTER & direction key(◀▶) |
| VCR / Alarm reset | AR RST |
| Group A/B selection | SHIFT + LV/PB |
| Quad / PIP screen | ENTER |
| Auto sequence | AUTO |
| Still image | FREEZE |

Function of Display

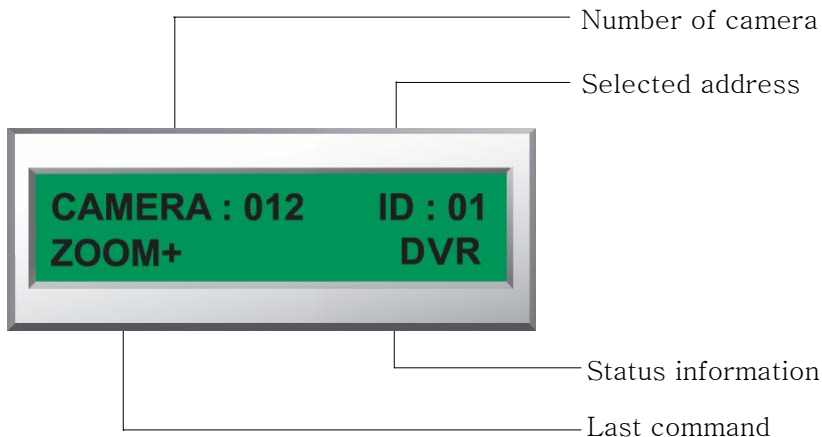

The following data is displayed:

- selected camera number

The currently selected camera number is displayed.
(CAMERA: 001-128/256)

- selected address

The currently selected address of the target client gets displayed
(ID: 01 – 99)

- Matrix system for main output of DVRs (ID: 17)
- Matrix system for spot output of DVRs (ID: 20))

- last command

The last command gets displayed.

- Status information

“MODE SEL” button changes the currently the mode of the controller.

- DVR (DVR mode): The speed dome camera can be controlled by each DVR via this controller.
- PTZ (PTZ mode): The speed dome camera can be controlled this controller.

Operating of Display

**SYSTEM CONTROL
FIRMWARE VER 1.0**

After power input it is a first screen.

**CAMERA:001 ID:01
■ DVR**

It is a condition which is set in initial DVR mode.
Left DVR LED comes to light.
PTZ button can not use.

**CAMERA:001 ID:01
■ PTZ**

Press the MODE SEL button make DVR mode change PTZ mode and left DVR LED off.

**PASSWORD:
■**

MODE SEL button when during 2 seconds it presses becomes the password input hold status.
Default value is 0000 & enter button.

**CAMERA:001 ID:01
SELECT ID:■**

Presses the ID button and presses 2 place numbers from in the number button and the monitor image is changed with correspondence DVR.
Becomes the DVR mode with automatic movement and the CAMERA number comes to erase.

**CAMERA:001 ID:01
SELECT CAM:■**

Presses the CAM button and presses 3 place numbers from in the number button and the monitor image is changed in corresponding Channel.

**CAMERA:001 ID:01
MON:2 CAM:■**

Presses the MON button and 2~5 until it presses 1 place number from in the number button and the DVR selection menu comes out and when 0~9 until it presses 3 place numbers from in the number button and the corresponding monitor is changed with corresponding camera image.

Menu setting of Display

SYSTEM SETUP

DVR SETUP

| | | | | | | |
|-----------------|------|------|------|------|-------|-------|
| 1. SPEED | 1200 | 2400 | 4800 | 9600 | 19200 | 38400 |
| 2. ID LINK MTXM | | | | | | |
| ID | 17 | 18 | 19 | | | |
| CH | 8 | 16 | | | | |
| 3. ID LINK MTXS | | | | | | |
| ID | 20 | 21 | 22 | | | |
| CH | 8 | 16 | | | | |
| 4. ID LINK DVR | | | | | | |
| ID | 01 | 02 | ~ | 99 | | |
| CH | 4 | 8 | 9 | 16 | | |
| 5. ID LINK TEST | | | | | | |

PTZ SETUP

| | | | | | | |
|----------------|---------|--------------|------|----------|-------|-------|
| 1. SPEED | 1200 | 2400 | 4800 | 9600 | 19200 | 38400 |
| 2. MODEL | NONE | SPD | | SRX-100B | | |
| | VC-C4R | SD-290 | | SCC-643 | | |
| | PELCO-D | DSC-230 | | CS-854 | | |
| | DMP23 | LPT-A100L | | PELCO-P | | |
| | BOSCH | TK-C655/C676 | | SK-D106 | | |
| | EZ | PCS-SERIES | | | | |
| 3. CH | 000 | 001 | ~ | 256 | | |
| ID | 001 | 001 | ~ | 999 | | |
| 4. INFORMATION | | | | | | |
| CH | 000 | | | | | |
| SUM | 000 | | | | | |

CTRL SETUP

| | | |
|----------------|----|-----|
| 1. BUZZER | ON | OFF |
| 2. PASSWORD | ON | OFF |
| MAKE PASSWORD | | |
| 3. F/W UPGRADE | | |
| 4. INITIALIZE | | |

How to connect the 256 CAMERA SYSTEM

A. General installation

Menu Setting

Setting MENUs among DVRs and PTZ Cameras

1. DVR MENU Setting

SYSTEM ID & OUTPUT MODE Setting of RS-485

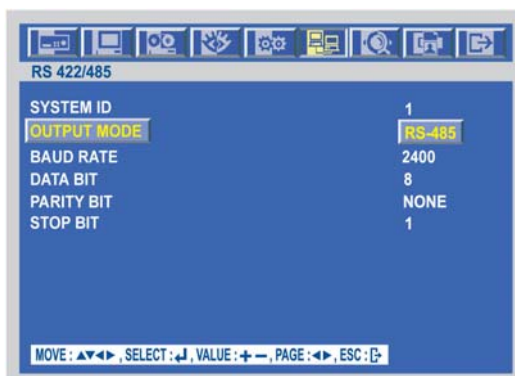
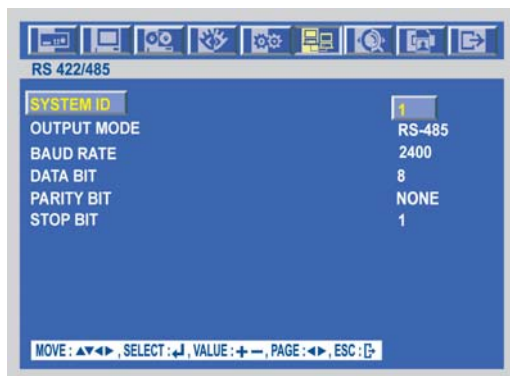

The SYSTEM ID sets the DVR especially different. **Set up ID (1-16)**

The Baud the rate sets with 9600. (Default 115200)

2. MATRIX & QUAD MENU Setting

There is not a necessity which it will change

Default speed 9600

Default ID 17

3. External Keyboard MENU Setting

The PTZ set the model name and the speed and the ID of the camera.

The PTZ set the Channel number where the video cable of the camera is connected.

(Channel number same to CAM + number + CAM)

Connection of RS485

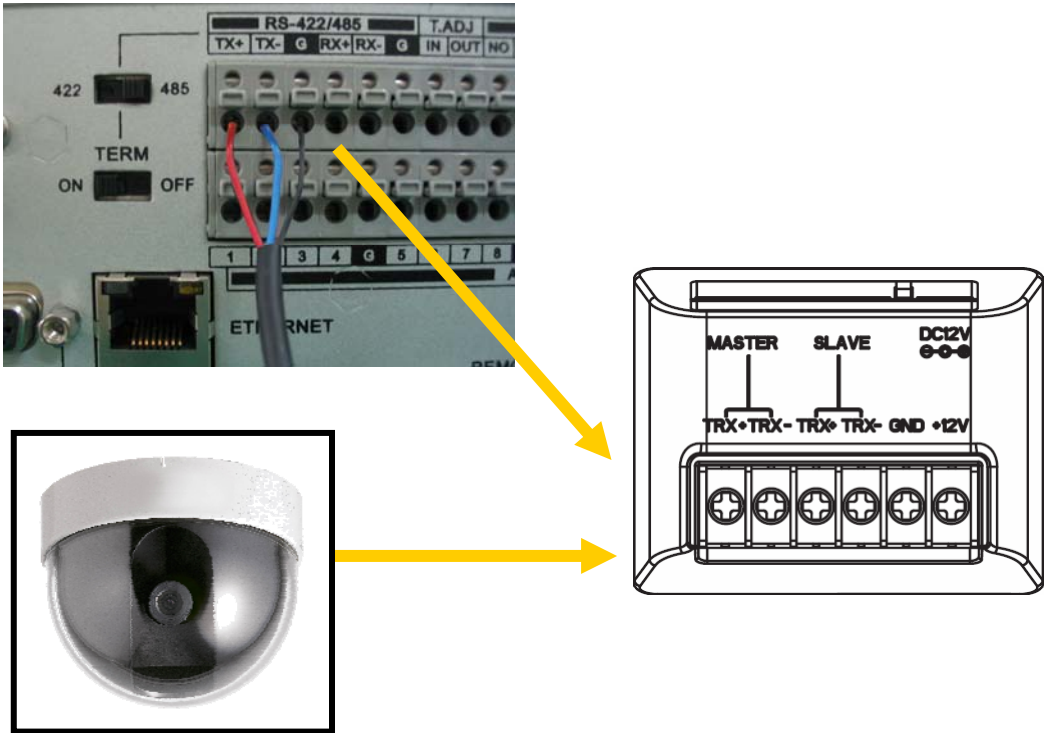

Connect RS485 of DVR and PTZ camera at JUNCTION BOX.
Not use RS232 of DVR.

The junction box and the controller connect with the RJ45 cable.

B. Control via DVR installation

Menu Setting

I. Setting MENUs among DVRs and PTZ Cameras

1. DVR MENU Setting

1) PTZ Camera Type, PTZ Camera ID & Speed Setting of RS-485

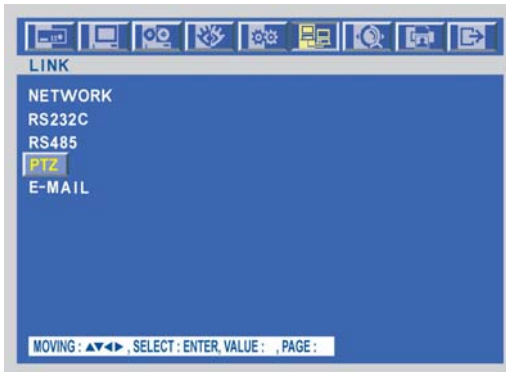

2) SYSTEM ID & OUTPUT MODE Setting of RS-485

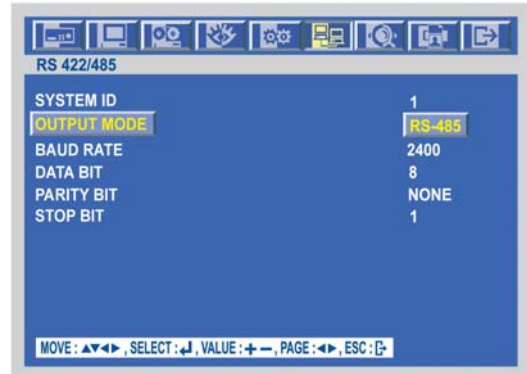
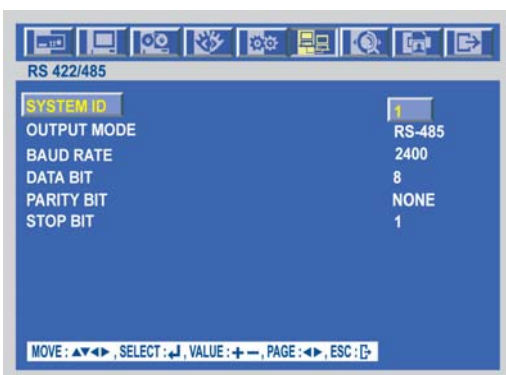

Set up ID(1-16), MODEL and BAUD RATE of the connected PTZ camera PTZ camera to connect and control a PTZ camera with DVR. And you have to set the OUTPUT MODE to RS-485.

II. MENU Setting among DVRs, Matrix and External Keyboard

1. DVR MENU Setting BAUD RATE Setting of RS-232

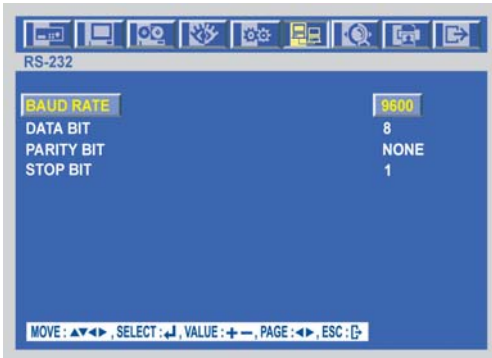

2. MATRIX or QUAD MENU Setting

There is not a necessity which it will change

Default speed 9600

Default ID 17

3. External Keyboard MENU Setting

There is not a necessity which it will change

If DVR Channel is 4, 8 and 9 must change channel of correspondence id.

Keyboard Controller BAUD RATE Set.

- 1) Press the **SHIFT** and **ID/CONTROLLER MENU** key.
- 2) Select the **COMM SPEED** as **9600** using joy stick of Keyboard.
- 3) **Default Value of BAUD RATE is 9600.**

Connection of RS485

Connection of Control Signal

1. Connecting the PTZ Camera with DVR:

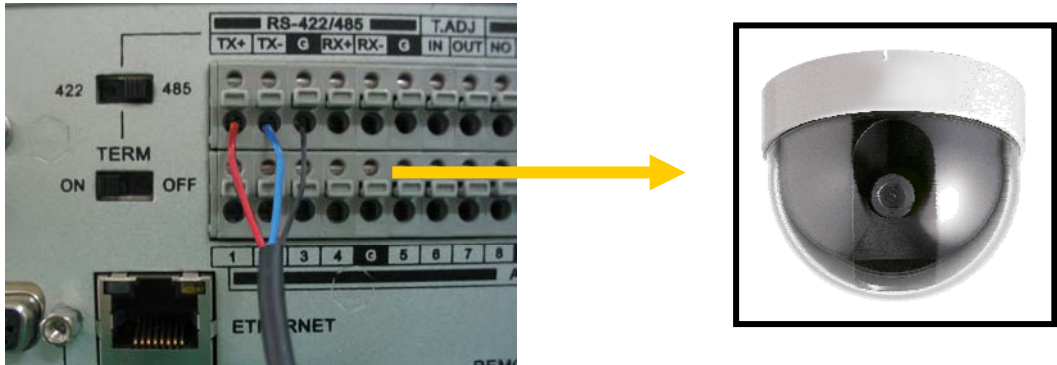

Connect the RS422/485 cable of PTZ camera with the terminal block of DVR.

2. Connecting a DVR or a Matrix to an External keypad controller:

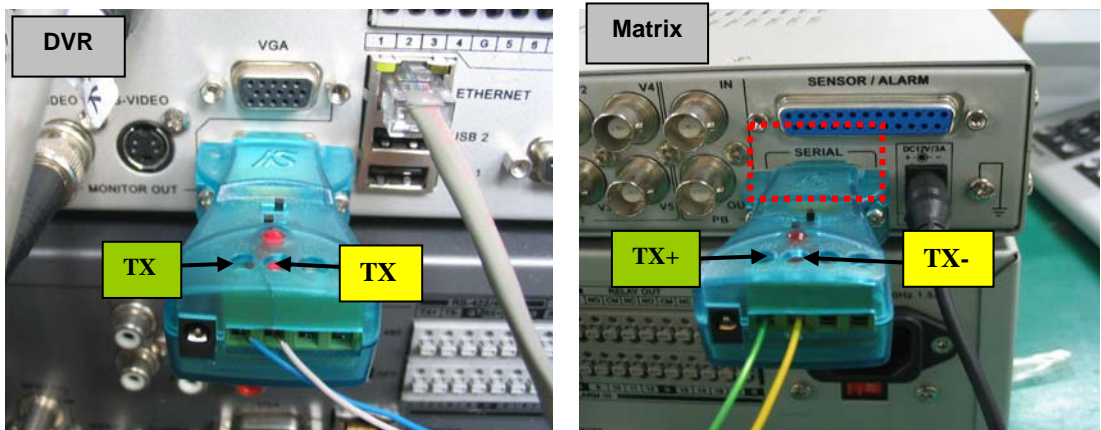

1. RS-232C Connection

(The SERIAL port of DVR or Matrix can connect RS-232C.)

2. RS-485 Connection

Connect the 485CONVERTER (RS-485 to RS-232C converter) to SERIAL port of DVR to connect with DVR.

3. Connect the + line of RS-485 to the TRX+ of 485CONVERTER and the - line of RS-485 to the TRX- of 485CONVERTER.

Connection of Video

1. Connecting the PTZ Camera with DVR:



Connect the VIDEO OUTPUT of PTZ Camera to CAMERA IN of DVR.

2. Connecting the DVR with Matrix:

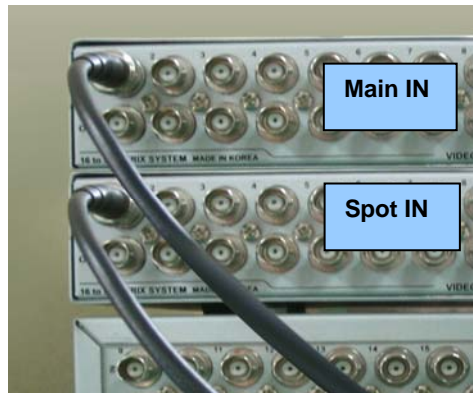
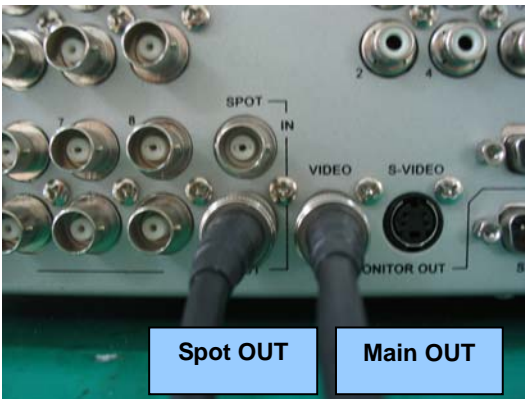

Connect the BNC connector of MONITOR OUTPUT to CAMERA IN of the Matrix for the Monitor and the BNC connector of SPOT OUTPUT to CAMERA IN of the Matrix for the SPOT Monitor.

3. Connecting a Monitor to a Matrix:

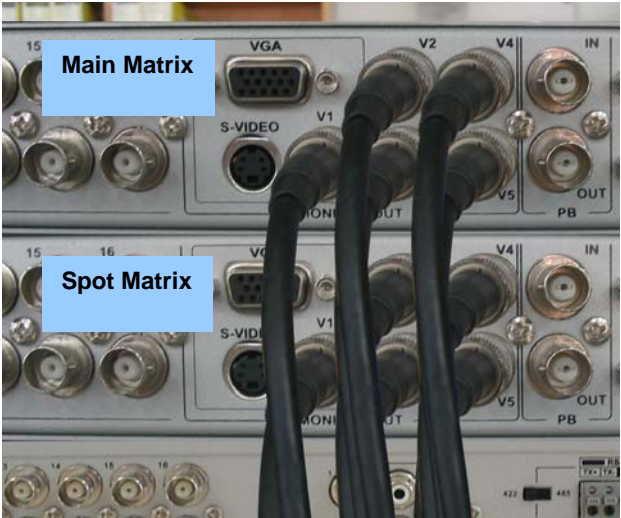

Main monitor



Spot monitor

Exhibit

Trouble shooting

Please contact your authorized dealer with an exact failure description if none of the below mentioned remedy measures fixes your problem.

| Error Description | Cause |
|---|---|
| No function | <ul style="list-style-type: none">- Not plugged in- Connects plug of the keyboard controller not connected- Incorrectly switched 120 Ohm termination resistor |
| No communication via RS485 interface | <ul style="list-style-type: none">- Incorrectly assigned device address of the client- Fault in the client's power supply- Missing or incorrect cable- Incorrectly switched 120 Ohm termination resistor |
| System crash | <ul style="list-style-type: none">- If twisted pair line is not shielded, interference may occur- Moving loads are plugged incorrectly- Power supply of one (several) clients is defective |

Technical Specifications

| | |
|--------------------------------|--|
| Application | RS485 transmitter for selection and control of a maximum of 100 RS485 clients with an unlimited number of control commands |
| Joystick | Yes (pan/tilt move and zoom wide/ tele control) |
| Display | 16 characters x 2 line LCD |
| Optic coupler | For RS485 |
| Housing Connection cord | Table desk housing 6 cores, 5m long, pre-assembled with Western plug |
| Operating voltage | 12V DC |
| Consumption | 3 W |
| Addressing | Adjustable via jumper or software |
| Output | RS485 interface / BUSTRONIC protocol |
| Operating temperature | -10° C up to + 55° C |
| Air humidity | < 90 % |
| IP rating / class | IP40 / Class III |
| MTBF | 80,000 hours |
| Dimensions (W x H x D) | 342 x 165 x 96.8 mm |
| Housing color | ABS / Black |
| Accessories (included) | operating instructions, Western socket |

Some Words on Excess-Voltage

Excess-voltage is the most common reason for defects in electronic equipment. That's why the additional safety precautions for the transmission devices mentioned in these instructions are so important. These safety precautions avoid or at least minimize short-lived voltage pulses (transients) on the data line.

Causes for excess-voltage:

- direct strikes by flashes of lightning
- indirect lightning strikes in distances of up to several kilometers
- switching acts in the energy net
- disturbances by house internal switching acts

The shielded line has to be conductive along the whole length of the connection distance and has to be grounded at least at both ends. Only a shield on both sides can reduce double reaction. The grounding of the shield has to be carried out with impedance as low as possible.

This avoids spikes of several 1,000 V caused by bad shield connection.

If wires go from one building to another their wire shields must be able to cope with high impulse currents for short periods of time. This can only work if the shield cross section is large enough. This can not be accomplished by foil sheets alone.

Multiple-shielded cables can reduce – but not avoid – residual interference on the signal leads.

Therefore, the use of additional charge eliminators is indispensable in most cases.

We recommend information technology devices!

Maintenance and Care

Disconnect this controller from power supply before starting to clean it. For reasons of electrical safety never clean the keyboard with water or other liquid matters and never put the device underwater. Only use a soft dry cloth for cleaning this controller.

A cleaning of this controller's interior may only be carried out by authorized personnel. Make sure to include these instructions when handing the unit over to third parties.

Technical Support

Please contact the authorized dealer.



Unit 39
Sir Frank White Business Centre
Great Central Way
Rugby
CV21 3XH

Tel : 0844 800 1725
Fax : 01788 544 549

Web Site www.plettac-security.co.uk

